



# DROP IN REPLACEMENT GUIDE

**GAS HEATERS**



OFFICIAL  
POOL  
EQUIPMENT  
SUPPLIER



## Why Jandy®?

Why settle for sufficient when you can get superior...  
With Jandy equipment, you're getting a product that's easy to install in most pool pads, compatible with most existing setups and provides unparalleled performance and efficiency.



### Protecting Your Bottom Line

We've got your back. Our equipment is **NOT** available for purchase on the internet. Only through you.



### Drops In with Ease

Jandy equipment is engineered to easily replace any existing equipment in the pool pad with minimal plumbing adjustments. Jandy is a trade-up, not just a trade out.



### Built to Last

Our equipment is designed for durability so you can get the job done and can trust that it will perform for the long haul.



### Support You Can Count On

With our superior customer service and dedicated training team available to you when you need it most, you'll never be caught off-guard on-site.

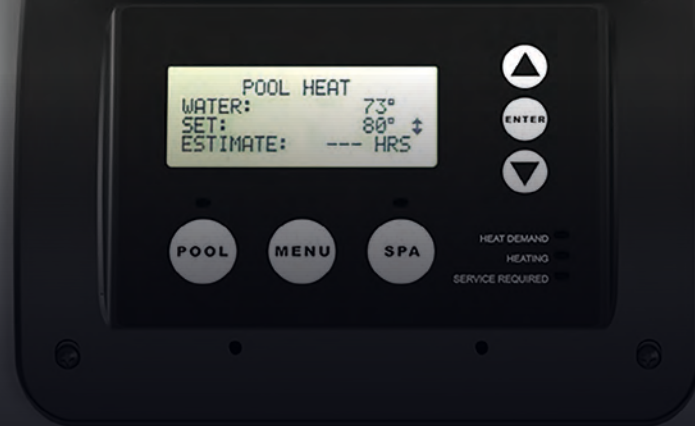

# Why JXiQ™ and JXi™ are the First Choice When Replacing a Heater



## Best Retrofit Option

3-port header for easy plumbing and drop-in replacement of Pentair® MasterTemp®.



## Flexible Installation

Top can be easily removed for increased accessibility and rotated 180 degrees so you never need to rotate headers.



## Ultra-Compact Lightweight Design

Fits on a 2' x 2' pad and is 38% lighter with a 28% smaller footprint.\*

\*Compared to popular competitor models.



## Keeps Critters Out

The JXiQ and JXi are made with a fully encased shell to protect against rodent intrusion and damage.

## Suggested Tools

- Pipe Wrench
- Channel Locks
- Phillips Screwdriver
- PVC Pipe Cutter
- Multimeter
- Manometer
- Impact Drill with Proper Bit
- Wire Cutter/Strippers



NOTE: Fluidra equipment must be installed and serviced by qualified or licensed pool professionals.  
Please see the installation manual for complete step-by-step instructions.

# MasterTemp® to JXiQ™ and JXi™ Comparisons

## Polymer Header - Copper Tubes

Pentair® MasterTemp®	BTU Input	Jandy® JXiQ™ and JXi™	BTU Input
200	199,000	JXi200N/JXi200P JXiQ200NK/JXiQ200PK	199,000
250	250,000	JXi260N/JXi260P JXiQ260NK/JXiQ260PK	260,000
300	300,000	JXi260N*/JXi260P* JXiQ260NK*/JXiQ260PK*	260,000
400	399,000	JXi400N/JXi400P JXiQ400N/JXiQ400P	399,000

\*If the current gas supply can handle the extra gas volume a JXi 400 can be used.

## Polymer Header - CuproNickel Tubes

Pentair® MasterTemp®	BTU Input	Jandy® JXi™	BTU Input
250	250,000	Currently N/A	-
400	399,000	JXi400NN/JXi400PN	399,000

## ASME Compliant Brass Header - Copper Tubes

Pentair® MasterTemp®	BTU Input	Jandy® JXiQ™	BTU Input
200	199,000	Currently N/A	-
250	250,000	JXiQ260NC/ JXiQ260PC	260,000
400	399,000	JXiQ400NC/ JXiQ400PC	399,000

## ASME Compliant Brass Header - CuproNickel Tubes

Pentair® MasterTemp®	BTU Input	Jandy® JXiQ™	BTU Input
200	199,000	Currently N/A	-
250	250,000	JXiQ260NS/ JXiQ260PS	260,000
400	399,000	JXiQ400NS/ JXiQ400PS	399,000

# JXiQ™ Parts

Item #	Description
R0457502	Jandy Igniter Kit, JXi
R0456502	JXiQ Inlet Temp Sensor
R0589700	Jandy Thermal Regulator Valve
R0592300	Jandy High Limit Temp Sensors
R0593400	Jandy Anchor Brackets
R0589500	Jandy Gasket & Seals Kit (Heater manifold)
R0456301	Jandy Transformer, JXi Replacement Kit
R0988700	JXiQ Ignition Controller Assembly

# JXi™ Parts

Item #	Description
R0457502	Jandy Igniter Kit, JXi
R0456500	Jandy Temperature Sensor Kit
R0589700	Jandy Thermal Regulator Valve
R0458100	Jandy Power Center PCB
R0592300	Jandy High Limit Temp Sensors
R0593400	Jandy Anchor Brackets
R0456900	Jandy Ignition Control Module
R0589500	Jandy Gasket & Seals Kit (Heater manifold)
R0456301	Jandy Transformer, JXi Replacement Kit
R0719500	Jandy JXi Power Interface Board (PIB), GEN2



# A Footprint That Fits Right In

## JANDY® JXiQ™ AND JXi™ DIMENSIONS

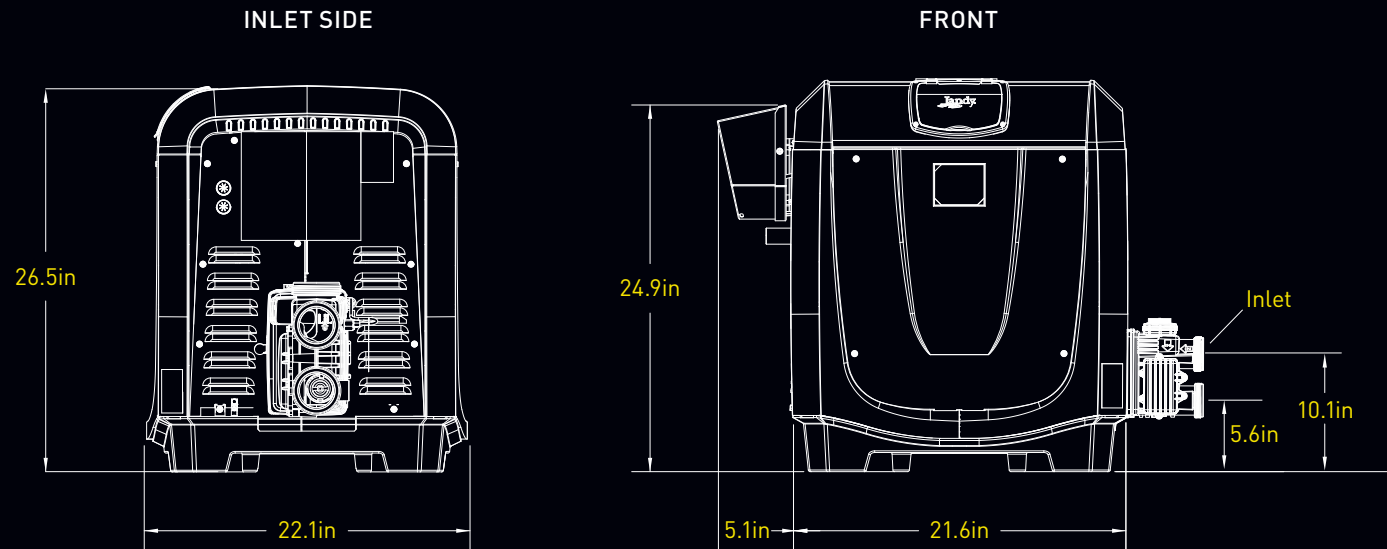

## PENTAIR® MASTERTEMP® DIMENSIONS

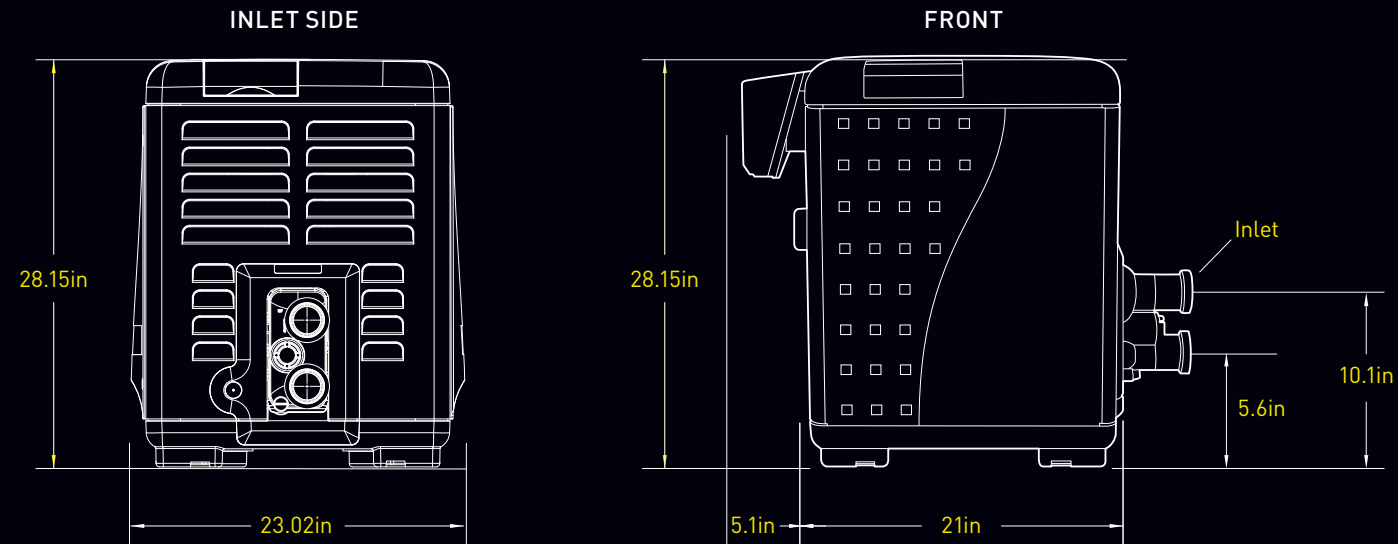

NOTE: Dimensions are identical on all JXi and JXiQ non-ASME compliant heater models

# Why Jandy® JXiQ™ is the Best Gas Heater



## Trouble-Free Troubleshooting

Connect with Bluetooth® to get full, real-time diagnostic capabilities displayed on the Fluidra® Pro App.



## VersaFlo™ Integrated Bypass Technology

Integrated Bypass technology automatically directs the flow of water through the heat exchanger when heat is needed and around the heater when heating is not needed

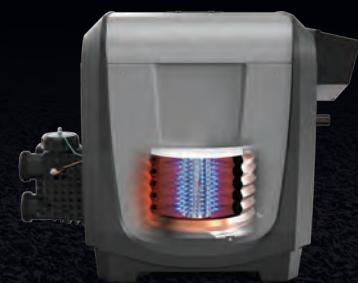

## Low Gas Pressure

Ensures there's enough gas pressure to safely ignite



## Auto-Sensing Power Input

Automatically adjusts to supplied power when installed, no cards to flip and no wires to change

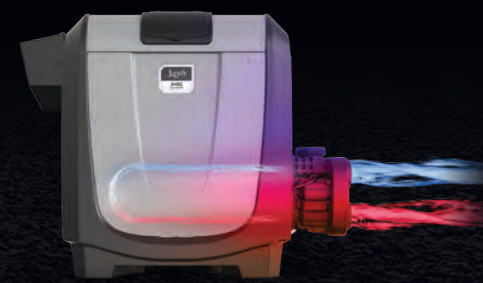

## Optimize Flow

Measures temperature rise between the inlet and outlet to optimize flow and avoid heat exchanger failures



DON'T LEAVE

# MONEY ON THE TABLE

SIGN UP TODAY &

GET THE **RIGHT TOOLS**

Fluidra's ServicePro Rewards Program is designed specifically for pool service companies and gives you access to the right tools, including marketing services, software, training and valuable consumer incentives — everything you need to grow your business.



SIGN UP NOW AND UNLOCK OVER **\$5,000 IN VALUE** INCLUDING:

 **\$50** Sign-Up Bonus

 **5%** Off First \$5,000

 **\$200** Back On Each VS Pump - Max. 5

 **\$200** Back On Each Automation - Max. 5

 **10%** Back On First \$1,000 Of Select Parts

 Plus **Many More** Exclusive Benefits

Sign up today!



[FluidraPro.com/Sign-Up](https://FluidraPro.com/Sign-Up)

**#DropInAJandy**

A Fluidra Brand | [Jandy.com](https://www.jandy.com) | 1.800.822.7933

©2025 Fluidra. All rights reserved. The trademarks and trade names used herein are the property of their respective owners. 67590.1 SL

